

## FLOORBOARD LAYOUT AND SPECIFICATION MORRIS EIGHT 1934-38

### Hopefully of use to those who do not have original boards as templates.

I quite often get queries regarding floorboard layout.

The following sketch drawings are accurate enough to be used to make your own boards, however I cannot guarantee an exact fit without some fettling.

They are based on the original items from my 1938 Series II Saloon. As far as I am aware these are similar to those used in the Two-Seater and Tourer versions; differences are likely around the toeboard area, at the body perimeters and towards the rear of the floor. They are shown for a right hand drive car and would need to be handed for left hookers. Similarly I have shown offside floorboards only to save time; nearside ones will be mirror images but will not require access apertures in the front nearside floorboard.

I have added (in red) significant differences on Tourer floorboards which are based on the original items from Tom Bourne's 1935 Pre-Series Tourer.

The sketch drawing show the upper faces of the boards; please note that the underside will require some clearance chamfers, shaping and counterboring (not shown) to provide clearance around rivet and bolt heads, chassis members and brackets, gearbox and pedals.

The positions of the inset brass locators for the carpet mat securing pins to the front footwells are shown marked with a +, and also shown are the access apertures for the brake master cylinder and pedal lubricator, and the rear spring lubricators where applicable. Access aperture covers were 1mm thick mild steel held with dome headed woodscrews all black enamelled.

The Front Floorboard and Lower Toeboard are bevelled and joined together using two obtuse angled metal brackets to each footwell set onto the board rear faces; originally these brackets were pre-formed and countersunk drilled and screwed. The Upper Toeboard and Lower Toeboard are rebated and overlapped together as shown.

Please note that the Seat Mounting Board does not abut the Front Floorboard or the Rear Floorboard, it sits between the two chassis cross rails which remain exposed.

Floorboards were originally made from 3/8" WBP bonded plywood and were sealed with a satin black preservative finish. They were laid directly onto the face of the chassis etc. after the steel propshaft/gearbox tunnels had been installed, without any sealing rubber or felt strips and held in place with suitable countersunk set screws and countersunk centred washers screwed into captive nuts in the chassis, propshaft/gearbox tunnels, rear underseat vertical panel and individual brackets. The Seat Mounting Board was originally wrapped in uncut moquette material to match the seat backs etc. and the adjacent section of propshaft tunnel (which was originally fixed to the chassis with rivets) was covered to match. All other floorboards were covered with carpet mats with the exception of the rear section of the Two-Seater which appears to have been uncovered.

The positions of the floorboard perimeter fixing holes are not shown, as ideally they should be drilled whilst fitting to ensure that they line up correctly with the captive nuts fitted to the chassis, propshaft/gearbox tunnels, rear underseat vertical panel and individual brackets.

# Floorboard Sketch Plan 1

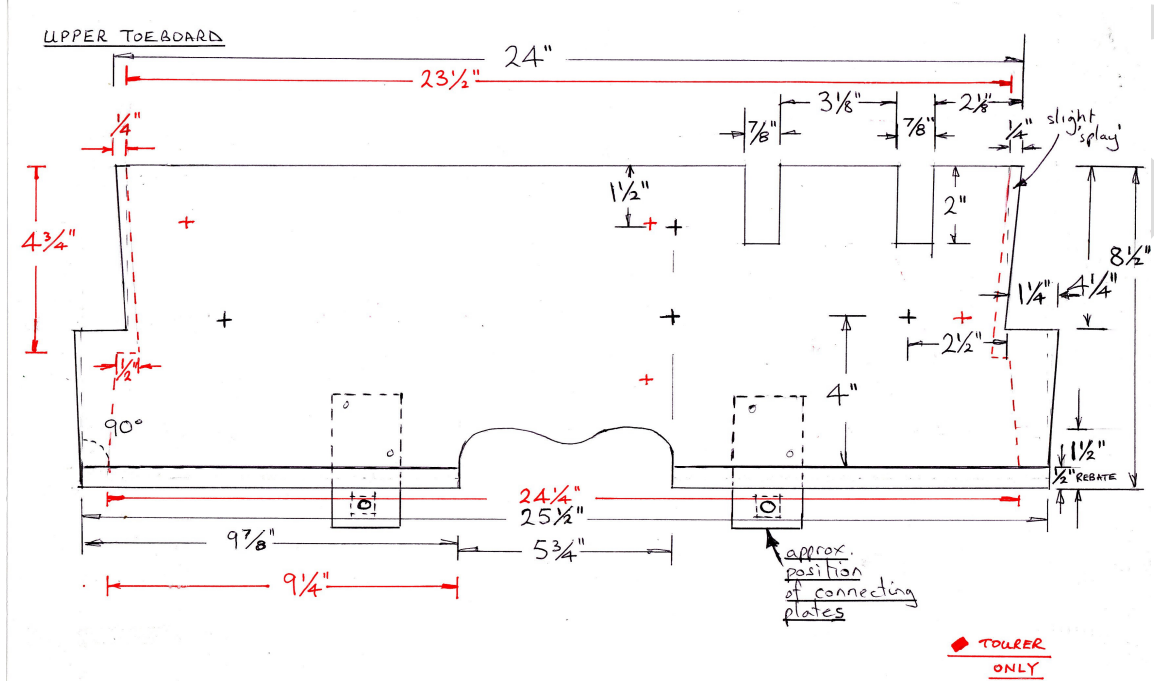

bob bryan

**Floorboard Sketch Plan 2**

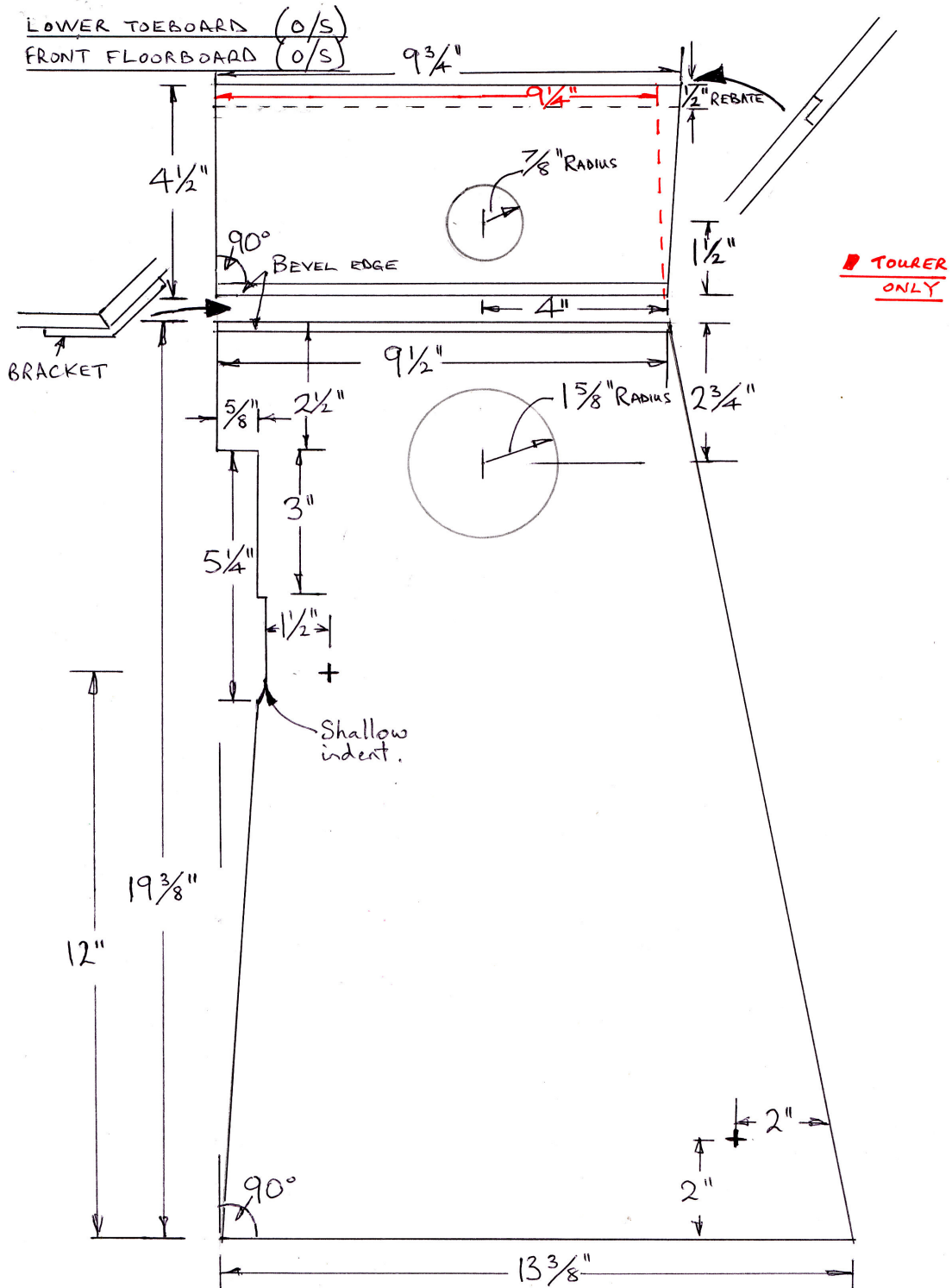

**Floorboard Sketch Plan 3**

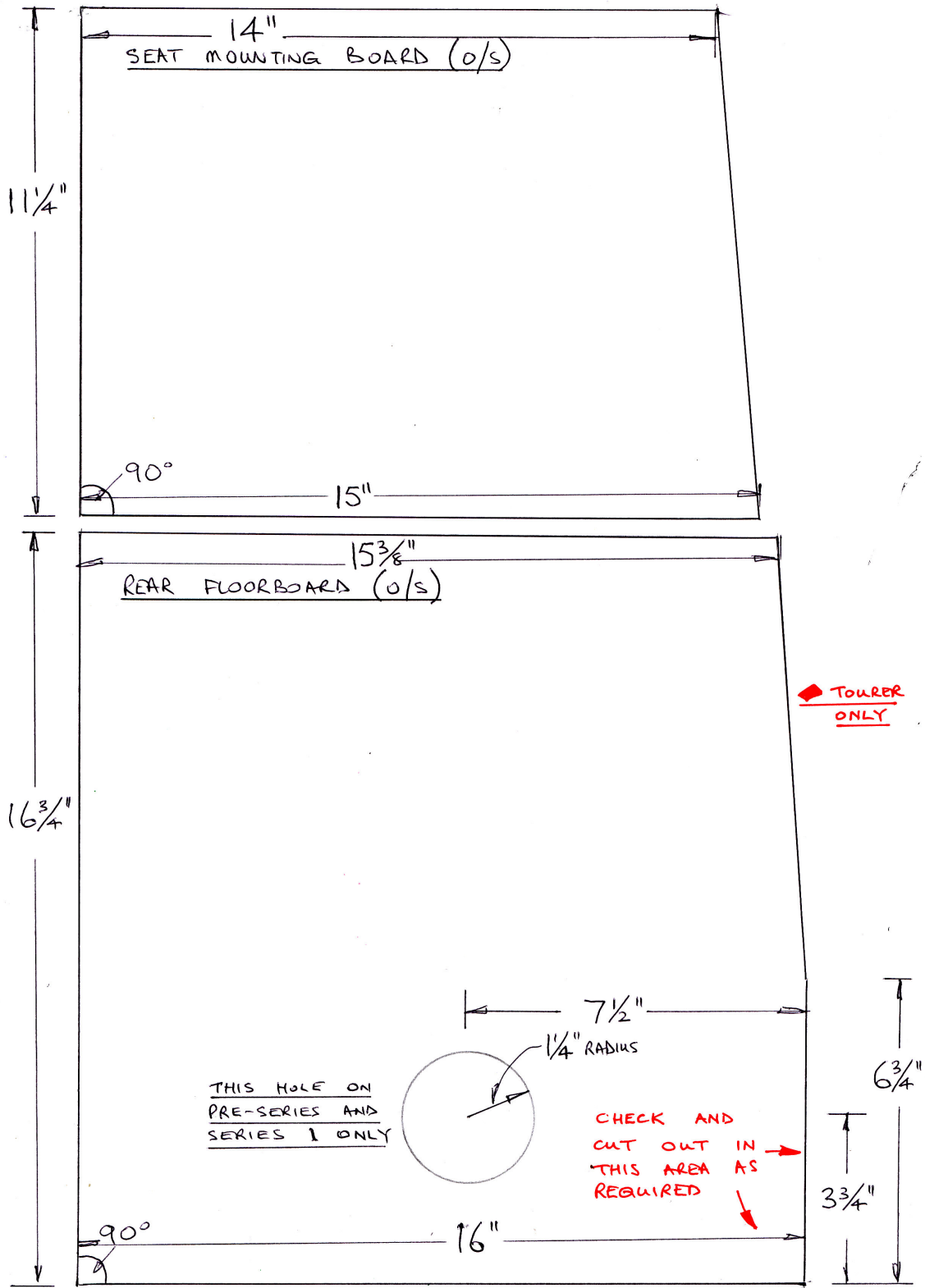

Floorboard Access Aperture Covers

8

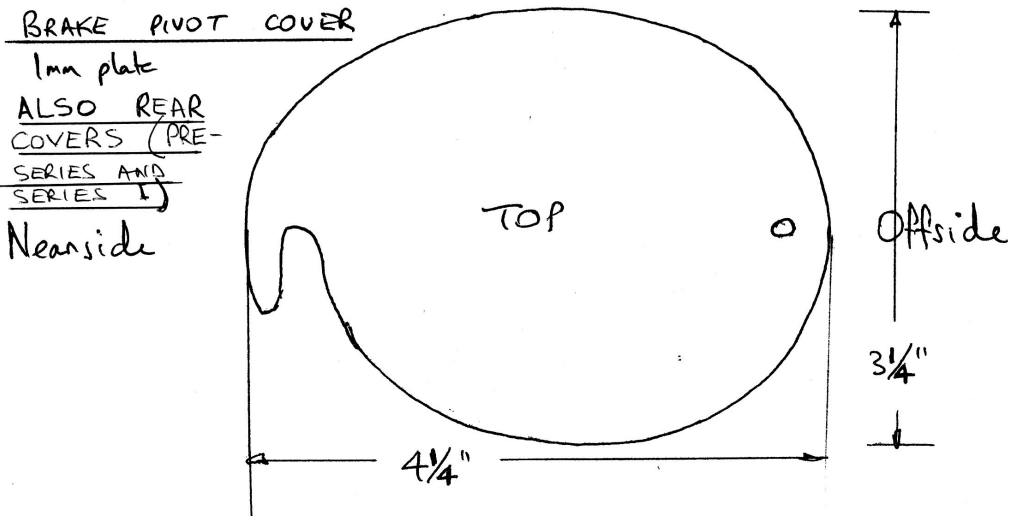
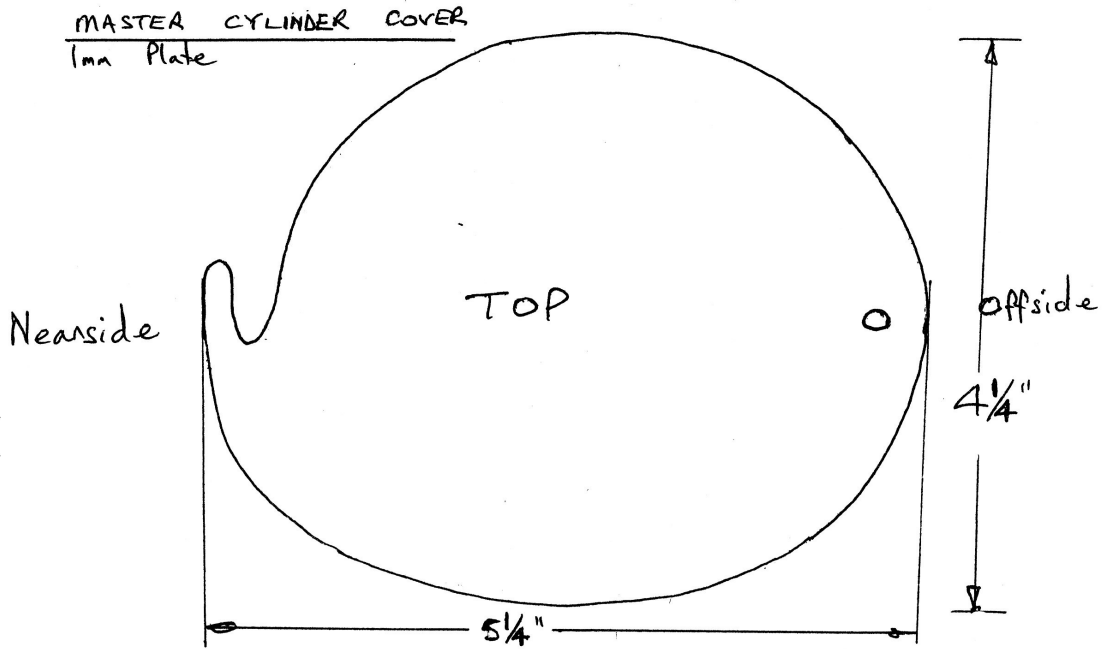

k

The information at my disposal at present is that all 1934-38 Morris 8 floorboards were fixed down using set screws and steel washers with a countersunk centre; the only boards that were fixed down with set screws and flush brass countersinks were those under the rear seat cushion. It is possible that early cars may have used these brass countersinks elsewhere; please let me know if you can show that this was the case.

I would appreciate constructive comments especially if you know something that I have missed! And any information regarding original floorboards for both Two-Seaters (no information as yet) and Tourers would be very useful.

It seems very likely that the Two-Seaters will have the same layout and specification as the Tourers.

**Important Footnote.**

And finally, because of the possibility of appreciable differences on individual cars, particularly the Two-Seaters and Tourers, please check the actual dimensions of the car in question before cutting the plywood!

**BOB BRYAN 2009**

**bobbryan@waitrose.com**